

SC15G Standard Compressor R134a 208-230V 60Hz

General

Code number	104G8526
Approvals	UL984
Compressors on pallet	80

Application

Application	MBP			
Frequency	Hz	50	60	
Evaporating temperature	°C	-	-25 to 10	
Voltage range	V	-	187 - 254	
Max. condensing temperature continuous (short)	°C	-	60 (70)	
Max. winding temperature continuous (short)	°C	-	125 (135)	

Cooling requirements

Frequency	Hz	50			60		
Application		LBP	MBP	HBP	LBP	MBP	HBP
32°C		-	-	-	-	F ₂	-
38°C		-	-	-	-	F ₂	-
43°C		-	-	-	-	F ₂	-
Remarks on application:							

Motor

Motor type	CSIR		
LRA (rated after 4 sec. UL984), HST LST	A	18.4	-
Cut in Current, HST LST	A	18.4	-
Resistance, main start winding (25°C)	Ω	4.2	14.6

Design

Displacement	cm ³	15.28
Oil quantity (type)	cm ³	550 (polyolester)
Maximum refrigerant charge	g	1300
Free gas volume in compressor	cm ³	1410
Weight without electrical equipment	kg	13.2

Dimensions

Height	mm	A	209
		B	203
		B1	183
		B2	100
Suction connector	location/I.D. mm angle	C	10.2 37°
	material comment	Copper Rubber plug	
Process connector	location/I.D. mm angle	D	6.5 37°
	material comment	Copper Rubber plug	
Discharge connector	location/I.D. mm angle	E	6.5 37°
	material comment	Copper Rubber plug	
Oil cooler connector	location/I.D. mm angle	F	-
	material comment	-	
Connector tolerance	I.D. mm		±0.09
Remarks:			

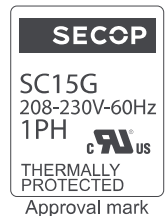
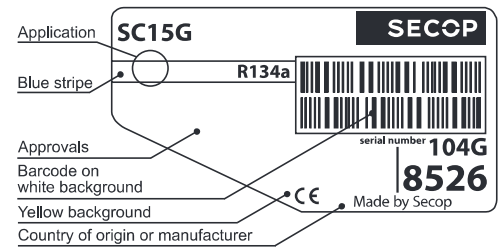

- S = Static cooling normally sufficient
- O = Oil cooling
- F₁ = Fan cooling 1.5 m/s (compressor compartment temperature equal to ambient temperature)
- F₂ = Fan cooling 3.0 m/s necessary
- SG = Suction gas cooling normally sufficient
- = not applicable in this area

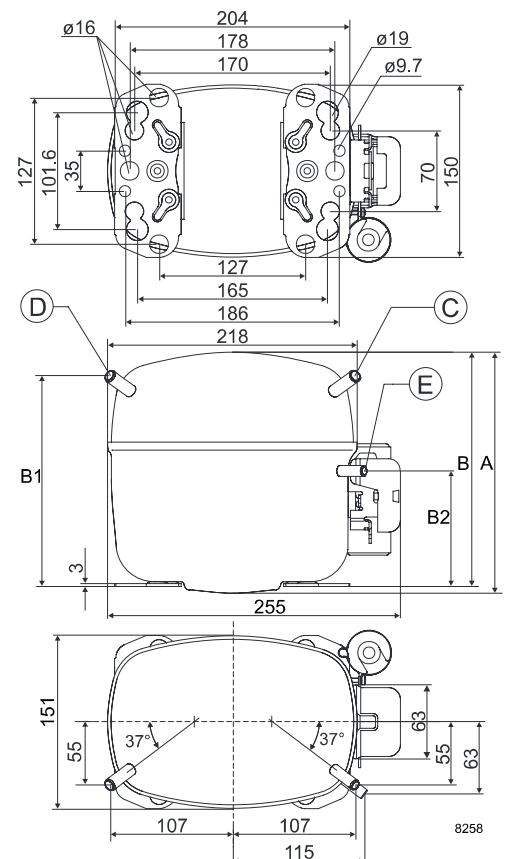

EN 12900 Household (CECOMAF) 230V, 60Hz, fan cooling F₂

Evap. temp. in °C	-45	-40	-35	-30	-25	-23.3	-20	-15	-10	-6.7	-5	0	5	7.2	10	15	20
Capacity in W					156	207	308	468	641	766	834	1049	1292	1409	1567		
Power cons. in W					241	269	323	399	470	513	534	591	642	662	685		
Current cons. in A					2.32	2.39	2.51	2.71	2.92	3.06	3.13	3.36	3.58	3.69	3.82		
COP in W/W					0.65	0.77	0.95	1.17	1.37	1.49	1.56	1.77	2.01	2.13	2.29		

ASHRAE MBP 230V, 60Hz, fan cooling F₂

Evap. temp. in °C	-45	-40	-35	-30	-25	-23.3	-20	-15	-10	-6.7	-5	0	5	7.2	10	15	20
Capacity in W					178	233	342	516	706	842	917	1153	1421	1550	1725		
Power cons. in W					241	269	322	398	468	510	531	588	639	659	682		
Current cons. in A					2.32	2.38	2.51	2.70	2.91	3.05	3.12	3.34	3.57	3.67	3.80		
COP in W/W					0.74	0.86	1.06	1.30	1.51	1.65	1.73	1.96	2.22	2.35	2.53		

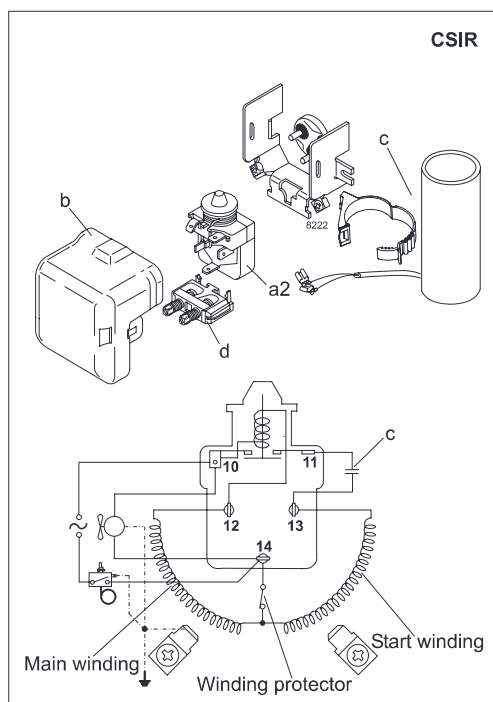

Accessories for	SC15G	Figure	Code number	Test conditions	EN 12900/CECOMAF	ASHRAE MBP
PTC starting device	6.3 mm spade connectors	a1	–	Condensing temperature	55°C	54.4°C
	4.8 mm spade connectors		–	Ambient temperature	32°C	35°C
Starting relay	6.3 mm spade connectors	a2	117U6011	Suction gas temperature	32°C	35°C
Cover		b	103N2008	Liquid temperature	no subcooling	46.1°C
Start. capacitor 80 µF	6.3 mm spade connectors	c	117U5017			
Cord relief		d	103N1004			
Protection screen for PTC		g	–			
				Mounting accessories	Code number	
				Bolt joint for one comp.	Ø: 16 mm	118-1917
				Bolt joint in quantities	Ø: 16 mm	118-1918
				Snap-on in quantities	Ø: 16 mm	118-1919

Secop can accept no responsibility for possible errors in catalogues, brochures and other printed material. Secop reserves the right to alter its products without notice. This also applies to products already on order provided that such alterations can be made without subsequential changes being necessary in specifications already agreed. All trademarks in this material are property of the respective companies. Secop and the Secop logotype are trademarks of Secop GmbH. All rights reserved. www.secop.com